

**WARRANTY
REGISTRATION**
Register online today for a chance
to win a FREE Tripp Lite product
www.tripplite.com/warranty



Owner's Manual

10U Wall-Mounted SmartRack™ Enclosure

Model: SRW10US



Table of Contents

1. Important Safety Instructions	2	6. Wall Mounting the Enclosure	6
2. Overview	2	6.1 Mounting	6
3. Feature Identification	3	7. Equipment Installation	7
4. Enclosure Installation	4	7.1 Installing or Removing Cage Nuts	7
4.1 Preparation	4	8. Optional Casters	7
4.2 Unpacking	4	9. Specifications	8
4.3 Placement	4	10. Storage and Service	8
4.4 Ground Connection	4	11. Warranty & Warranty Registration	8
5. Enclosure Configuration	5	Español	9
5.1 Door Locks	5	Français	17
5.2 Cable Access & Management	5		
5.3 Reversing the Enclosure	5		
5.4 Mounting Rails	5		
5.5 Adjusting Mounting Rail Depth	6		



1111 W. 35th Street, Chicago, IL 60609 USA
www.tripplite.com/support

1. Important Safety Instructions



SAVE THESE INSTRUCTIONS

This Manual contains instructions and warnings that must be followed during the installation and operation of the product described in this manual. Failure to comply may invalidate the warranty and cause property damage or personal injury.

- Keep the enclosure in a controlled indoor environment, away from moisture, temperature extremes, flammable liquids and gasses, conductive contaminants, dust and direct sunlight.
- Leave adequate space at the front and rear of the enclosure for proper ventilation. Do not block, cover or insert objects into the external ventilation openings of the enclosure.
- The enclosure is extremely heavy. Use caution when handling the enclosure. Do not attempt to unpack, move or install it unassisted.
- Do not place any object on the enclosure, especially containers of liquid, and do not attempt to stack the enclosures.
- Inspect the shipping container and the enclosure for shipping damage. Do not use the enclosure if it is damaged.
- Leave the enclosure in the shipping container until it has been moved as close to the final installation location as possible.
- Install the enclosure in a structurally sound area capable of handling the load, or on a level floor that is able to bear the weight of the enclosure, all equipment that will be installed in the enclosure and any other enclosures and/or equipment that will be installed nearby.
- Use caution when cutting packing materials. The enclosure could be scratched, causing damage not covered by the warranty.
- Save all packing materials for later use. Repacking and shipping the enclosure without the original packing materials may cause product damage that will void the warranty.
- Do not reship the enclosure with additional equipment unless the enclosure was shipped with a special shock pallet (“SP1” models only). The combined weight of the enclosure and installed equipment must not exceed the load capacity of the pallet. Tripp Lite is not responsible for any damage that occurs during reshipment.
- Use of this equipment in life support applications where failure of this equipment can reasonably be expected to cause the failure of the life support equipment or to significantly affect its safety or effectiveness is not recommended. Do not use this equipment in the presence of a flammable anesthetic mixture with air, oxygen or nitrous oxide.

If installing optional casters (SRCASTER—see page 7 for caster installation):

- The casters are designed for minor position adjustments within the final installation area only. The casters are not designed for moving the enclosure over longer distances.
- When rolling the enclosure on its casters, always push it from behind; never pull it toward you.
- A rolling enclosure can cause personal injury and property damage if not properly supervised. If rolling the enclosure down a ramp is required, use extreme caution. Do not attempt to use ramps that have a slope steeper than 1:12.

2. Overview

SmartRack Enclosures accommodate all standard 19-inch rackmount equipment, regardless of vendor, and ship fully assembled for quick and easy deployment.

3. Feature Identification

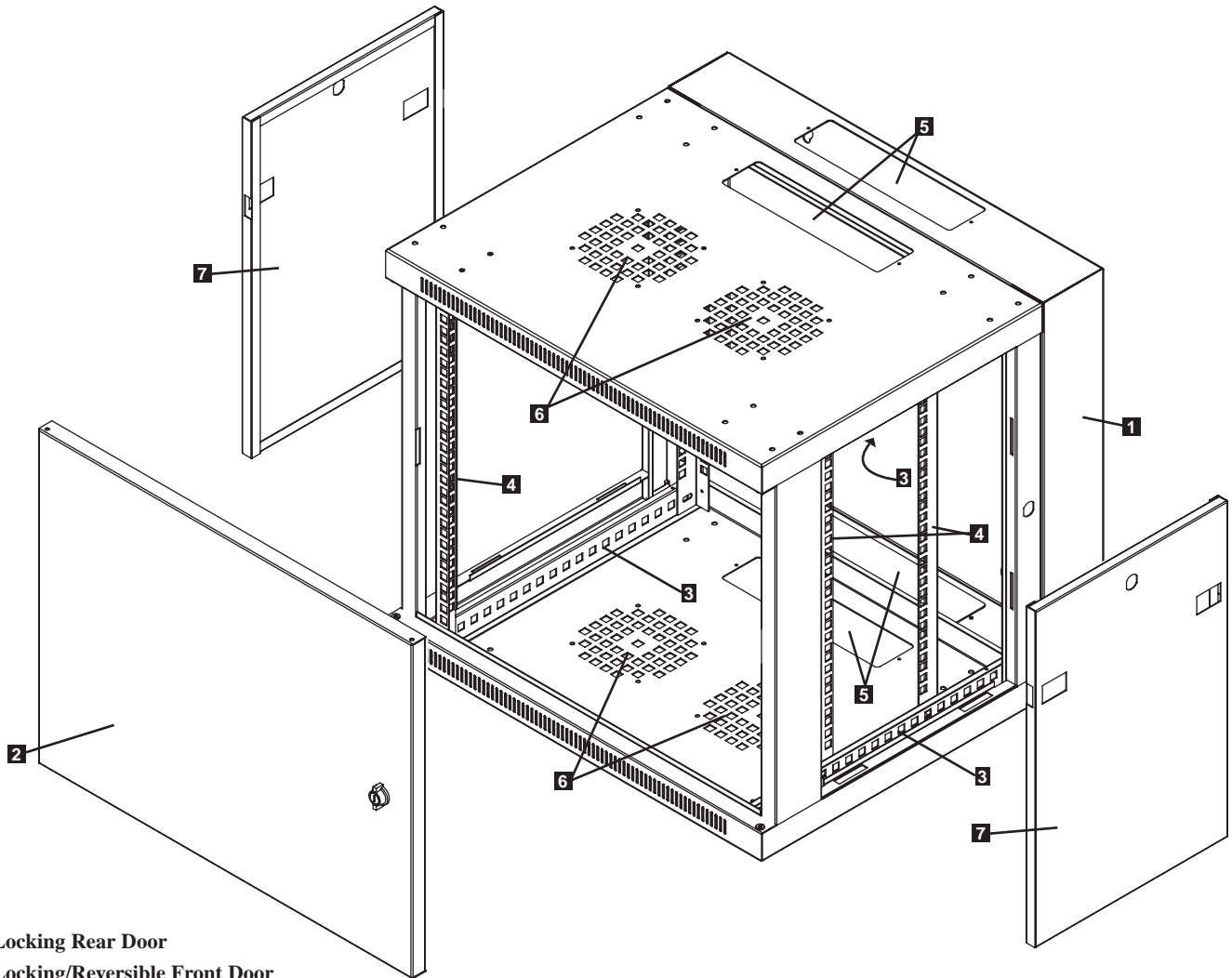

- 1** Locking Rear Door
- 2** Locking/Reversible Front Door
- 3** Horizontal Rails
- 4** Vertical Mounting Rails
- 5** Removeable Cable Access Hole Covers
- 6** Vents
- 7** Locking/Removeable Side Panels

4. Enclosure Installation



Caution! Read All Instructions and Warnings Before Installation!



Warning: Rack enclosures can be extremely heavy. Do not attempt to unpack, move or install the enclosure without assistance. Use extreme caution when handling the enclosure and be sure to follow all handling and installation instructions. Do not attempt to install equipment without first stabilizing the enclosure.

4.1 Preparation

The enclosure must be installed in a structurally sound area that is able to bear the weight of the enclosure, all the equipment that will be installed in the enclosure and any other enclosures and/or equipment that will be installed nearby. Before unpacking the enclosure, you should transport the shipping container closer to the final installation location to minimize the distance you will need to move the unit after the protective packaging has been removed. If you plan to store the enclosure for an extended period before installation, follow the instructions in the **Storage and Service** section.

You need several tools:

- Level
- Phillips-head Screwdriver
- Appropriate tools for wall mounting

You also need the following hardware:

- Appropriate hardware for wall mounting (not included)

Note: The hardware used in mounting the enclosure must be able to withstand the weight of the enclosure and all mounted equipment. For the weight of the enclosure and its capacity, see the specifications on page 8.

4.2 Unpacking



Use at least two people to unpack the enclosure.



- 1 Move shipping box to a firm, level surface.
- 2 Open box and remove the corner protectors. Save all packing materials for later use unless you are certain they will not be required. Packing materials are recyclable.
- 3 With one person on each side, carefully lift the enclosure out of the box and place on a firm, level surface.
- 4 Examine the enclosure for any damage or loose parts. Confirm all parts are present. If anything is missing or damaged, contact Tripp Lite for assistance. Do not attempt to use the enclosure if it has been damaged.

4.3 Placement

If using the optional casters, you can use the casters to move the enclosure for a short distance over a level, smooth, stable surface. Do not attempt to roll the enclosure over long distances. The enclosure should be moved close to its installation location inside its shipping container before it is unpacked.



**Warning: Never attempt to lift or install without adequate help.
Do not try lifting the enclosure alone.**



4.4 Ground Connection

All parts of the enclosure are grounded to the frame of the enclosure. Connect your facility's earth ground connection to the provided ground stud **A** using an 8 AWG (3.264 mm) wire. **Warning: Attach each enclosure to earth ground separately. Do not use the enclosure without an earth ground connection.**

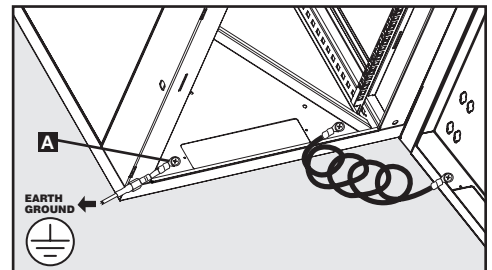

5. Enclosure Configuration

5.1 Door Locks

All enclosure doors (including front and back doors, as well as both side panels) have locks that are accessible by included keys.

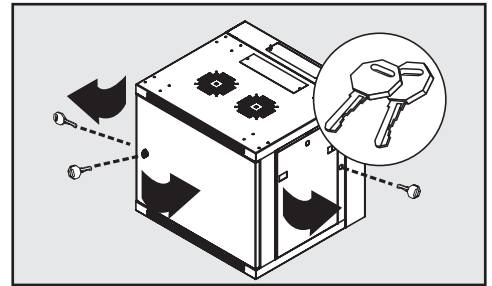

5.2 Cable Access and Management

The back door of the enclosure has a square opening for cable access and management. An additional opening can be found on top of the main cabinet. Each opening can also be closed by screwing in the removeable cable access panels.

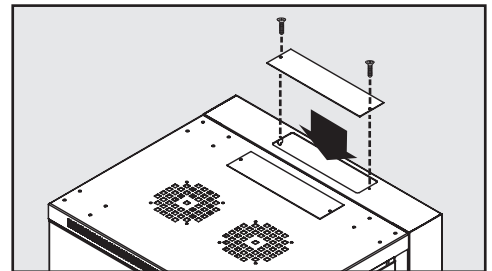

5.3 Reversing the Enclosure

In order to accommodate various rack configurations, the enclosure can be reversed. To do so, simply turn the enclosure over so that the doors open in the opposite direction.

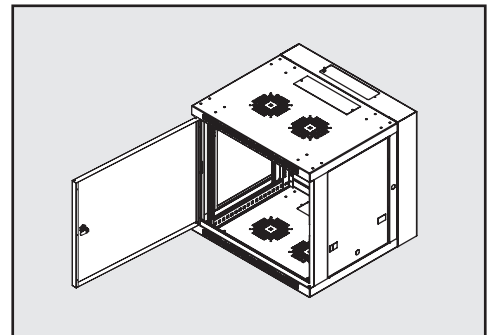
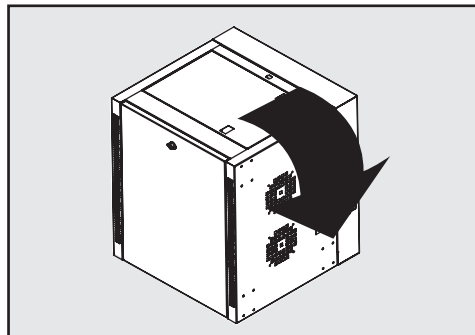
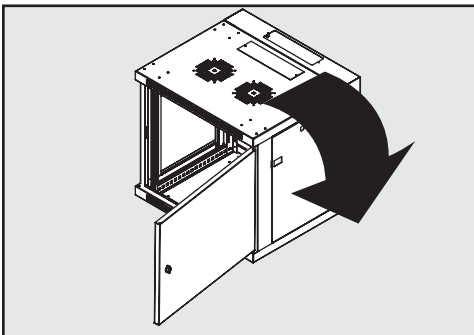

5.4 Mounting Rails

The enclosure comes with mounting rails that have square holes for mounting rack equipment. To install equipment, use the included cage nuts and other hardware. (See page 7 for installation of cage nuts.)

Warning: Be sure to have the enclosure securely mounted to the wall, or in its final position on the floor before mounting any equipment inside. Also be sure to have all the right adjustments on your rails before mounting equipment. (See below for Adjusting Mounting Rail Depth.)

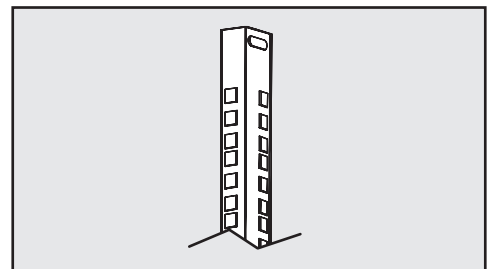

5. Enclosure Configuration *(continued)*

5.5 Adjusting Mounting Rail Depth

Warning: Do not attempt to adjust rails while equipment is installed in the enclosure. Do not attempt to use rails without screws installed. (2 per rail.)

The 4 mounting rails are pre-installed to accommodate equipment with a mounting depth of 20.5 inches (521 mm). Do not adjust the mounting rails unless your equipment requires a different mounting depth. The front and rear sets of rails can be adjusted independently for mounting of equipment with depths between 3 inches (76 mm) and 20.5 inches (521 mm).

- 1 Each rail is connected to the enclosure with 2 screws: 1 in the upper corner and another in the lower corner. Using a Phillips-head screwdriver, remove the screws that fasten the rails to the enclosure.
- 2 Slide the mounting rails to the desired depth and reattach them using the screws you removed in Step 1.

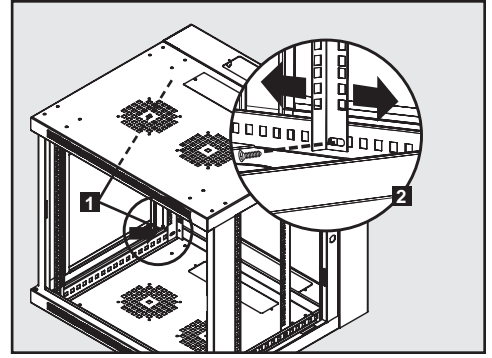

6. Wall Mounting the Enclosure

Warning: Do not attempt to mount the enclosure to the wall with equipment mounted in the enclosure.

6.1 Mounting

There are 16 keyhole cutouts on the back door of the enclosure. Each keyhole can accommodate an M10 or 3/8" bolt. The holes are centered and beginning with the two innermost holes, the centers are 12.625", 14.875", 17.125" and 19.375" apart, respectively moving outward and horizontally. Holes are then 17.858" apart vertically, as shown in the diagram.

Using a level, measure to position your mounting areas precisely. Use appropriate fasteners (not included) to secure the enclosure to the wall. **Warning:** The hardware you plan to use and the area you plan to mount the enclosure to must be able to withstand the weight of the enclosure and all mounted equipment. For the weight of the enclosure and its capacity, see the specifications on page 8.

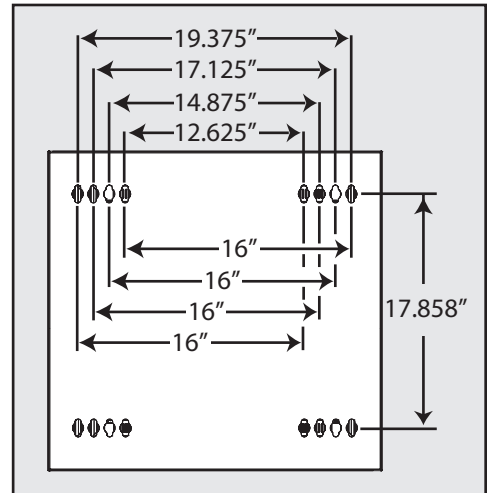

7. Equipment Installation

Warning: Do not install equipment until you have stabilized the enclosure. Install heavier equipment first and install it towards the bottom of the enclosure. Install equipment starting from the bottom of the enclosure and proceeding toward the top of the enclosure - never the reverse. If using sliding equipment rails, be careful when extending the rails. Do not extend more than one set of sliding equipment rails at one time. Avoid extending sliding equipment rails near the top of the enclosure.

Note: The square holes in the middle of each rack unit are numbered and also include a small notch to aid identification. A single rack unit includes the space occupied by the numbered hole and the holes directly above and below.



7.1 Installing or Removing Cage Nuts

WARNING: The flanges of the cage nuts should engage the sides of the square opening in the rail, not the top and bottom. Follow the instructions in your equipment documentation to ensure proper installation of your equipment.

1 Locate the numbered square openings in the mounting rails where you plan to install your equipment. You will install cage nuts (included) into the square openings in order to provide an attachment point for the mounting screws (included). *Note: Consult your equipment documentation to determine how many cage nuts will be required and where they will need to be installed.*

2 From the inside of the mounting rail, insert one of the flanges of the cage nut through the square opening. Press it against the side of the square opening. Each flange should engage one side of the square opening, not the top or bottom.

3 Compress the cage nut at the sides slightly to allow the remaining flange to fit through the square opening. When the cage nut is properly installed, both flanges will protrude through the square opening and will be visible on the outer surface of the mounting rail. Repeat steps 1-3 until all required cage nuts are installed.

4 After installing the required cage nuts, use the included mounting screws and cup washers to secure your equipment to the rack rail. Place the cup washers between the screws and the equipment mounting brackets.

Note: Your equipment may also include mounting hardware. Read the mounting instructions that came with your equipment before installing your equipment.

To Remove Cage Nuts, Reverse Steps 1-3

Note: You may wish to use a cage nut tool (user-supplied) to aid cage nut installation and removal.

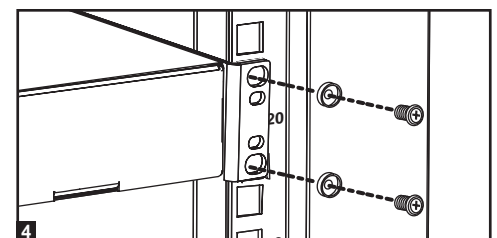
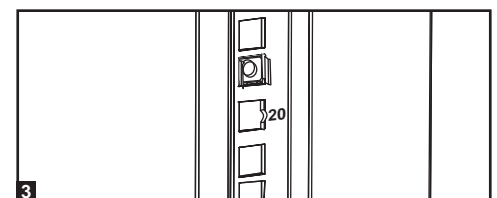
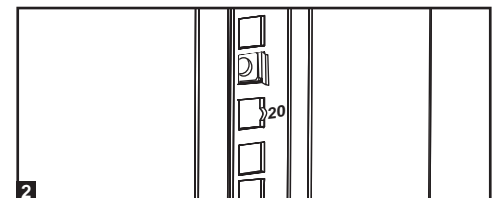
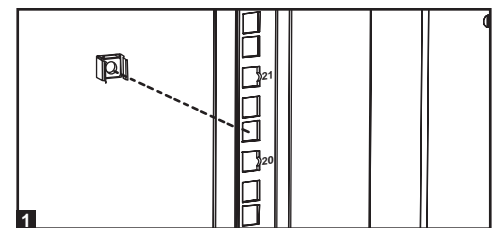

8. Optional Casters

An optional caster accessory kit (**Model: SRCASTER**) is available separately through Tripp Lite. Go to www.tripplite.com for details. The SRCASTER Kit consists of 4 casters with required locknuts and bolts for installation. The casters install to the base of the unit using pre-drilled holes as shown in the illustration below. For further installation instructions, refer to the manual included with the SRCASTER Kit.

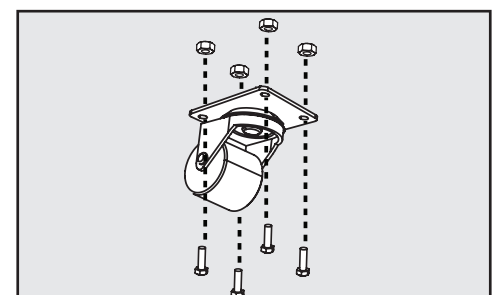

9. Specifications

Model	SRW10US
Dimensions (H x W x D)	21.6 x 23.63 x 21.6" (548 x 600 x 549 mm)
Unit Weight	55 lb (25 kg)
Load Capacity*	200 lb (90 kg) Stationary or Rolling
Mounting Depth (Adjustable)	3" to 20.5" (76 to 521 mm)

* Full wall-mount load capacity requires a mounting surface capable of bearing the full load. Rolling applications require optional SRCASTER accessory kit.

10. Storage and Service

Storage

The enclosure should be stored in a controlled indoor environment, away from moisture, temperature extremes, flammable liquids and gasses, conductive contaminants, dust and direct sunlight. Store the enclosure in its original shipping container if possible.

Service

Your Tripp Lite product is covered by the warranty described in this manual. A variety of Extended Warranty and On-Site Service Programs are also available from Tripp Lite. For more information on service, visit www.tripplite.com/support. Before returning your product for service, follow these steps:

1. Review the installation and operation procedures in this manual to insure that the service problem does not originate from a misreading of the instructions.
2. If the problem continues, do not contact or return the product to the dealer. Instead, visit www.tripplite.com/support.
3. If the problem requires service, visit www.tripplite.com/support and click the Product Returns link. From here you can request a Returned Material Authorization (RMA) number, which is required for service. This simple on-line form will ask for your unit's model and serial numbers, along with other general purchaser information. The RMA number, along with shipping instructions will be emailed to you. Any damages (direct, indirect, special or consequential) to the product incurred during shipment to Tripp Lite or an authorized Tripp Lite service center is not covered under warranty. Products shipped to Tripp Lite or an authorized Tripp Lite service center must have transportation charges prepaid. Mark the RMA number on the outside of the package. If the product is within its warranty period, enclose a copy of your sales receipt. Return the product for service using an insured carrier to the address given to you when you request the RMA.

11. Warranty and Warranty Registration

5-Year Limited Warranty

Seller warrants this product, if used in accordance with all applicable instructions, to be free from original defects in material and workmanship for a period of 5 years from the date of initial purchase. If the product should prove defective in material or workmanship within that period, Seller will repair or replace the product, at its sole discretion.

THIS WARRANTY DOES NOT APPLY TO NORMAL WEAR OR TO DAMAGE RESULTING FROM ACCIDENT, MISUSE, ABUSE OR NEGLIGENCE. SELLER MAKES NO EXPRESS WARRANTIES OTHER THAN THE WARRANTY EXPRESSLY SET FORTH HEREIN. EXCEPT TO THE EXTENT PROHIBITED BY APPLICABLE LAW, ALL IMPLIED WARRANTIES, INCLUDING ALL WARRANTIES OF MERCHANTABILITY OR FITNESS, ARE LIMITED IN DURATION TO THE WARRANTY PERIOD SET FORTH ABOVE; AND THIS WARRANTY EXPRESSLY EXCLUDES ALL INCIDENTAL AND CONSEQUENTIAL DAMAGES. (Some states do not allow limitations on how long an implied warranty lasts, and some states do not allow the exclusion or limitation of incidental or consequential damages, so the above limitations or exclusions may not apply to you. This warranty gives you specific legal rights, and you may have other rights which vary from jurisdiction to jurisdiction).

WARNING: The individual user should take care to determine prior to use whether this device is suitable, adequate or safe for the use intended. Since individual applications are subject to great variation, the manufacturer makes no representation or warranty as to the suitability or fitness of these devices for any specific application.

Warranty Registration

Visit www.tripplite.com/warranty today to register the warranty for your new Tripp Lite product. You'll be automatically entered into a drawing for a chance to win a FREE Tripp Lite product!*

* No purchase necessary. Void where prohibited. Some restrictions apply. See website for details.

Tripp Lite has a policy of continuous improvement. Specifications are subject to change without notice.



1111 W. 35th Street, Chicago, IL 60609 USA
www.tripplite.com/support